

## Application of "easy" Simulation in Cold Forging

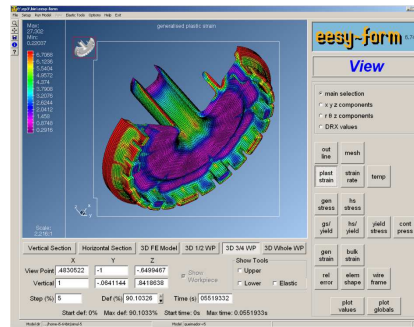

*Dr. Gerhard H. Arfmann, Dr. Michael Twickler  
CPM GmbH, Herzogenrath, Germany*

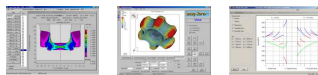

## Application of "easy" Simulation in Cold Forging



Automotive parts made by Forging

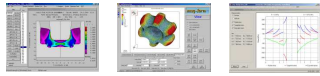

### Application of FEA Simulation in Cold Forging

How to design the right process  
to produce a forged part?

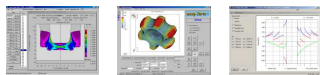
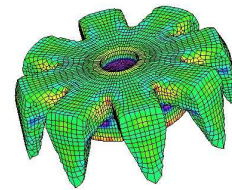

### Application of FEA Simulation in Cold Forging

Starting from the product drawing the engineer has to

**design the forming sequence,  
chose the machine and  
designs the tooling.**

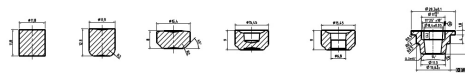

Traditionally he starts his work from **some initial design** and orders **the tooling**.

After arrival of them he starts with **the try out**.

After **some trial and error cycles** the engineer works out the  
**final process and tool design.**

Bild: XZB, Hangzhou, PR China



## Application of FEA Simulation in Cold Forging

### Process Idea

The process idea normally comes from the design engineer.

He may generate it from

- his own knowledge
- experience
- from books
- information from third parties.

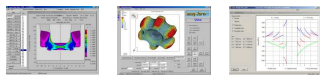
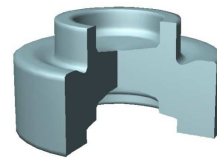

## Application of FEA Simulation in Cold Forging

### Initial Design

Normally the engineer adjusts existing designs to the requirements of the new part.

More rarely he develops a new process design from the roots.

**Available design packages** based on empirical basic technology and/or on stored example progressions may help him as well.

**However the engineer has to come up with an initial design layout.**



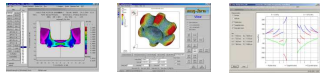

## Application of FEA Simulation in Cold Forging

### Principle of process design

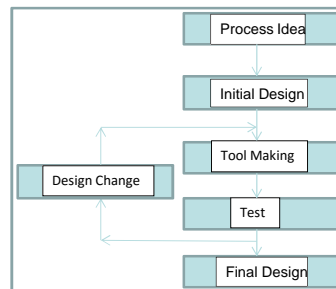

As published by the author in the 1980's to explain how future CA techniques may help the engineer

**In some cases all the testing is wasted and the product cannot be produced.**

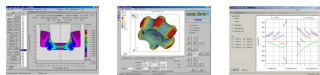

## Application of FEA Simulation in Cold Forging

### The role of Finite Element Analysis (FEA) in Process Design

FEA supports the engineer to generate better designs:

- the engineer models his ideas in FEA
- he finds out whether his process idea will work
- technological information (Stresses, Strain, Flowlines..) enables him to optimize his design
- he can try alternative ideas
- he can study the tool design and can optimize that as well.



**Result: The Process is optimized before ordering the tools even.**

Further: In case of no success the development can be stopped before wasting time on endless trials.

In any case FEA helps to avoid costs.

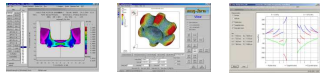

## Application of FEA Simulation in Cold Forging

How good is FEA?

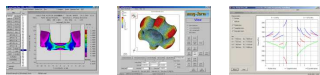
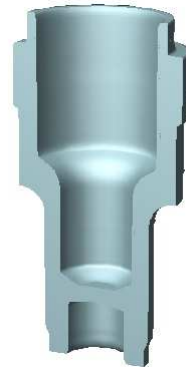

## Application of FEA Simulation in Cold Forging

FEA is:

- precise enough to avoid trial and error
- quick enough to accelerate developments significantly (reduce the dev. Time)
- is more precise than the "firm" knowledge of experienced stuff
- helping to close the gaps in knowledge of the stuff
- having the required data (material, friction etc) available and proved
- practically exact even so scientifically not 100% precise
- providing the stuff much more insight in the process than any imagination of an experienced stuff
- best used by experienced stuff and will help to improve their technology
- .....

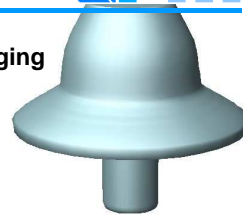

**FEA is the ideal tool for the good engineer!**

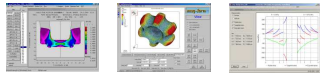

## Application of FEA Simulation in Cold Forging

For what to use FEA?

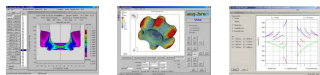
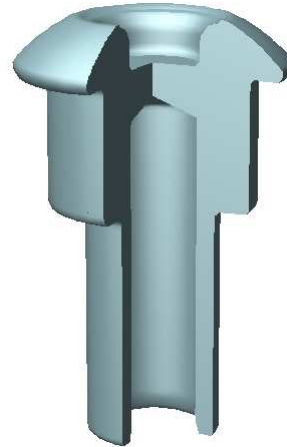

## Application of FEA Simulation in Cold Forging

The following examples deal with very real cases to show the advantage of the use of FEA.

They are of different complexity and therefore show that the use of FEA is not only beneficial for complex applications.

**All cases are recent applications of customers.**

**All of customers are long time in the market and have a sound reputation as good technology companies.**

**They provided these examples to show that consequent and continuous usage of FEA is a "must" in state of the art cold forging.**

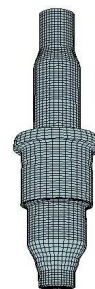

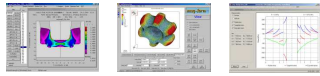

## Application of FEA Simulation in Cold Forging

### Design of a Process to form a Cylinder Head Bolt

The following bolt had to be produced:

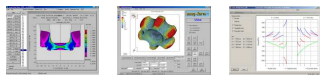
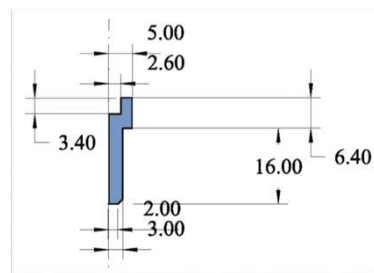

## Application of FEA Simulation in Cold Forging

### Design of a Process to form a Cylinder Head Bolt

Using his knowledge and/or some support tools the engineer came up with his first approach to produce the fastener.

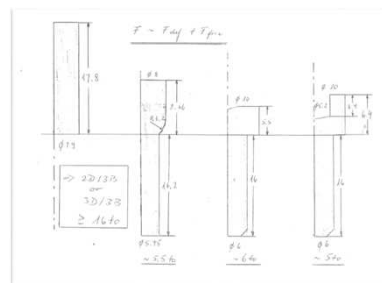

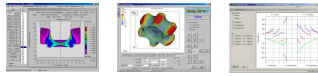

### Application of FEA Simulation in Cold Forging

#### Design of a Process to form a Cylinder Head Bolt

Simulations performed showed a bad (but typical) result:

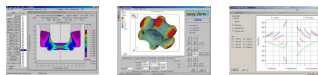
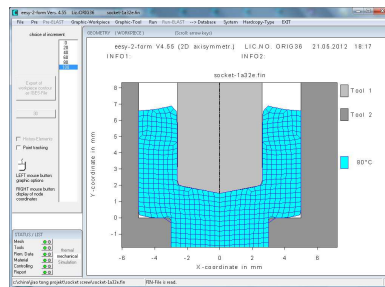

### Application of FEA Simulation in Cold Forging

#### Design of a Process to form a Cylinder Head Bolt

Simulation based on empirical knowledge showed a bad result as well:

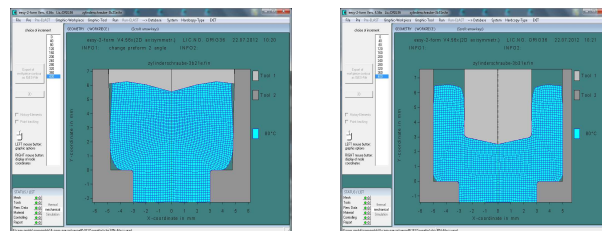



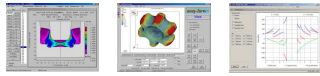

### Application of FEA Simulation in Cold Forging

#### Design of a Process to form a Cylinder Head Bolt

Detailed studies of the material flow in several variations let to a good result:

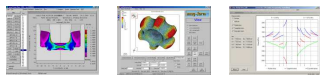
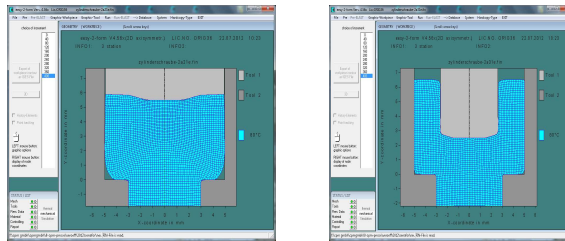

### Application of FEA Simulation in Cold Forging

#### Design of a Process to form a Cylinder Head Bolt

Simulation

Real part.

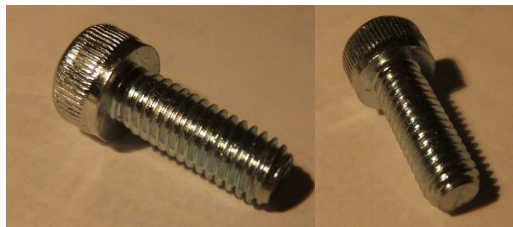
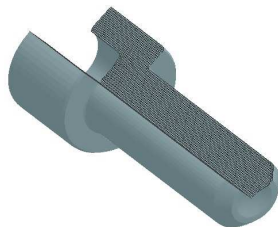

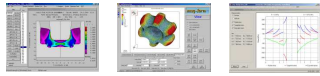

### Application of FEA Simulation in Cold Forging

#### Design of a Process to form a Spark Plug – practical example



Simulation

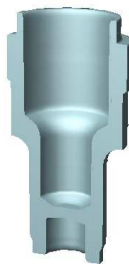

Real part.

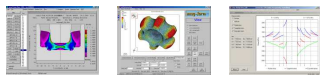

### Application of FEA Simulation in Cold Forging

#### *Production of a shock absorber*

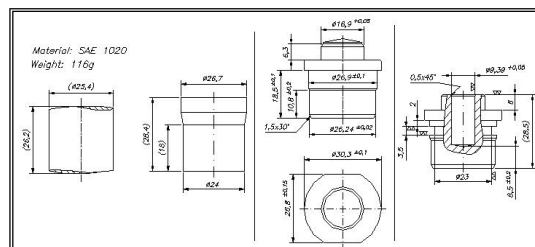

Conventional process

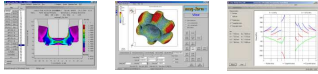

## Application of FEA Simulation in Cold Forging

### *Production of a shock absorber*

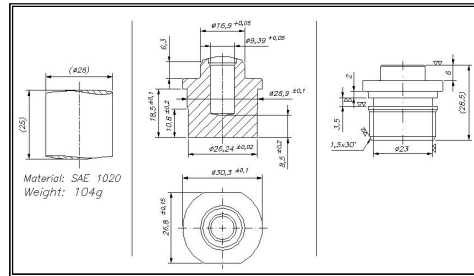

### Single stage process

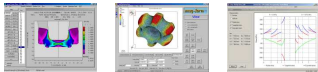

## Application of FEA Simulation in Cold Forging

### *Production of a shock absorber*

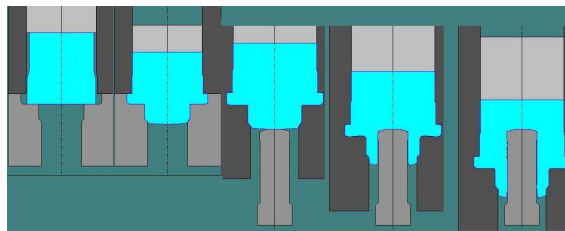

### Simulation of the single stage process

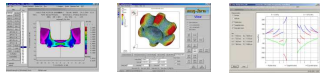

## Application of FEA Simulation in Cold Forging

### *Production of a shock absorber*

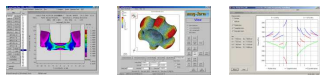
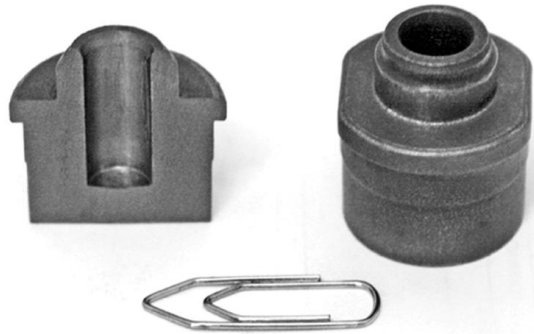

## Application of FEA Simulation in Cold Forging

### *Production of a shock absorber body*



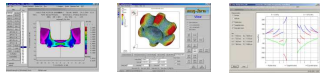

**Application of FEA Simulation in Cold Forging**

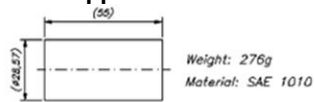

**Production of a shock absorber body**

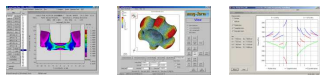
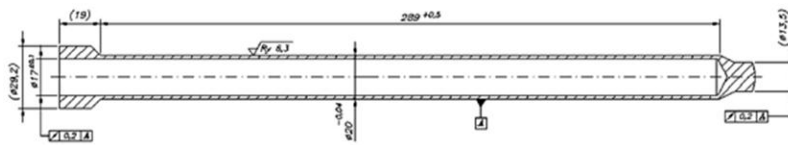
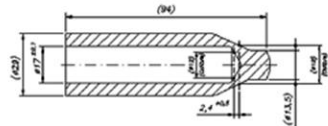

**Application of FEA Simulation in Cold Forging**

**Production of a valve spring retainer – tool failure**

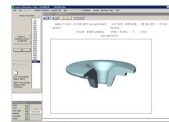

**Progression**



**Premature tool failure**

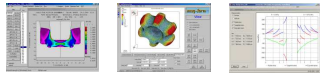

## Application of FEA Simulation in Cold Forging

### Production of a valve spring retainer – tool failure

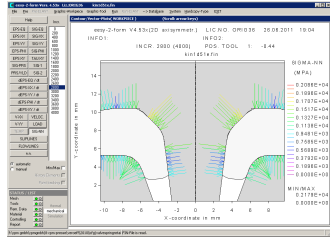
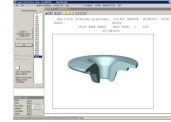

Normal Stresses

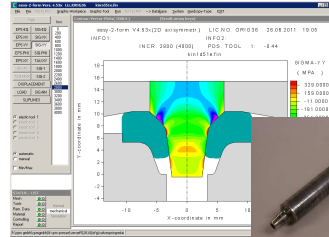

Axial Stress in the punch



(c) 2014 Dr. Gerhard H. Arfmann, Dr. Michael Twickler  
Presentation, 10.09.2014, Shanghai, PR China

27

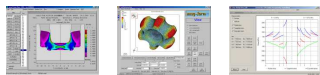

## Application of FEA Simulation in Cold Forging

### Production of a nut

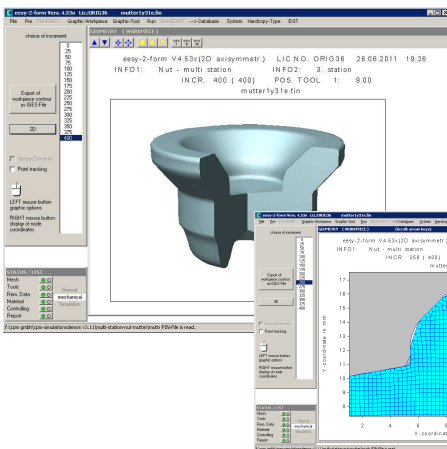

Premature tool failure

(c) 2014 Dr. Gerhard H. Arfmann, Dr. Michael Twickler  
Presentation, 10.09.2014, Shanghai, PR China

28

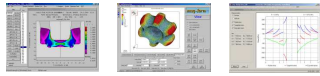

### Application of FEA Simulation in Cold Forging

#### *Roughness and cracking on a valve spring retainer*

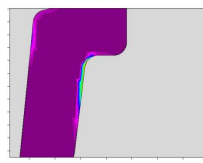

surface enlargement

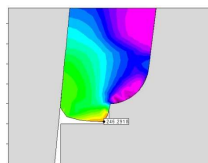

high tangential stress

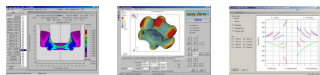

### Application of FEA Simulation in Cold Forging

#### *Production of a „bolt“*

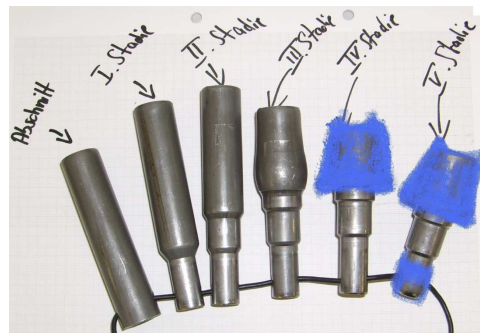

Premature tool failure in station 4

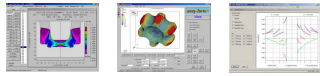

### Application of FEA Simulation in Cold Forging

#### Production of a „bolt“

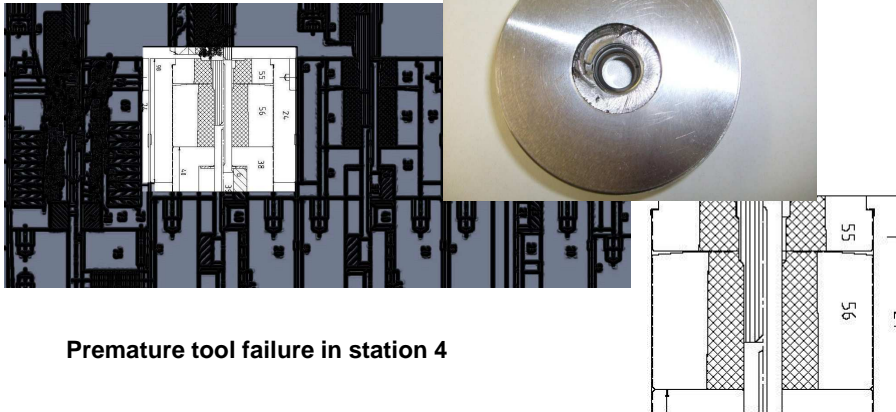

Premature tool failure in station 4

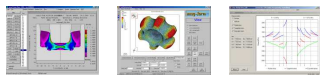

### Application of FEA Simulation in Cold Forging

#### Production of a „bolt“

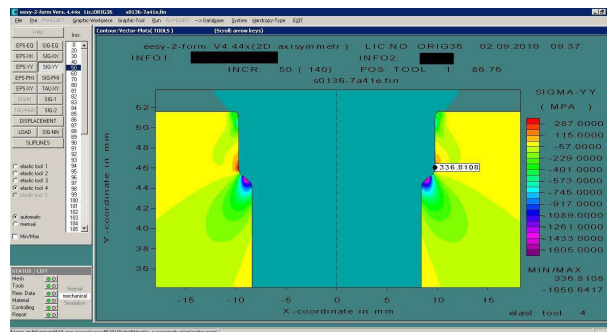

Positive stress in station 4 – 5.000 pieces tool life



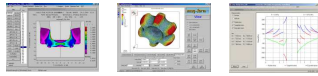

## Application of FEA Simulation in Cold Forging

### Production of a „bolt“

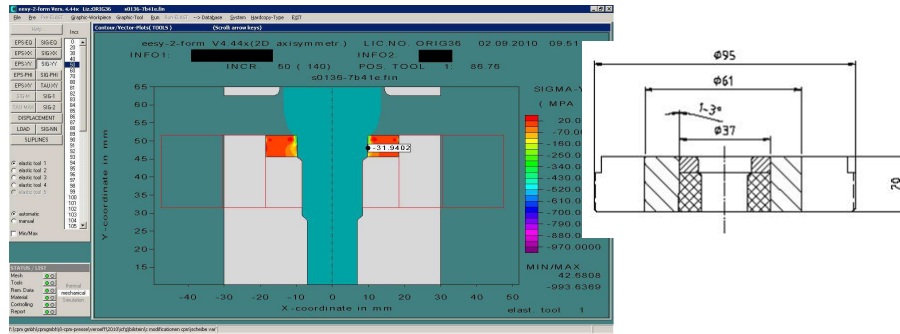

Compressive stress in station 4 – new design – 100.000 pieces tool life

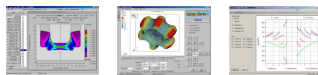

## Application of FEA Simulation in Cold Forging

### Design of an extrusion die



Overloaded die insert

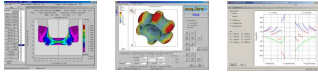

## Application of FEA Simulation in Cold Forging

### *Design of an extrusion die*

Practical example

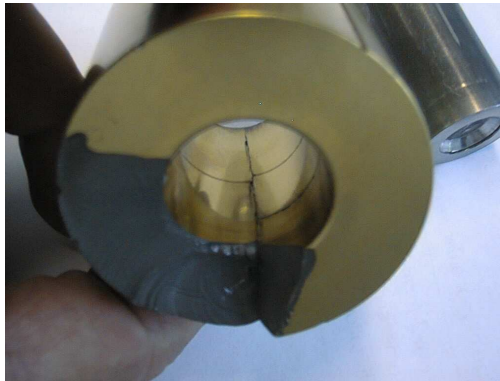

Overloaded die insert

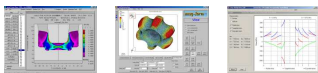

## Application of FEA Simulation in Cold Forging

### *Production of a bolt*

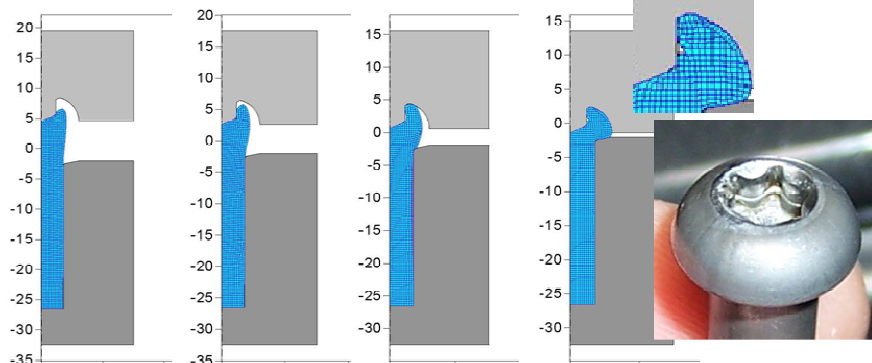

Original progression with folding



### Application of FEA Simulation in Cold Forging

#### *Production of a bolt*

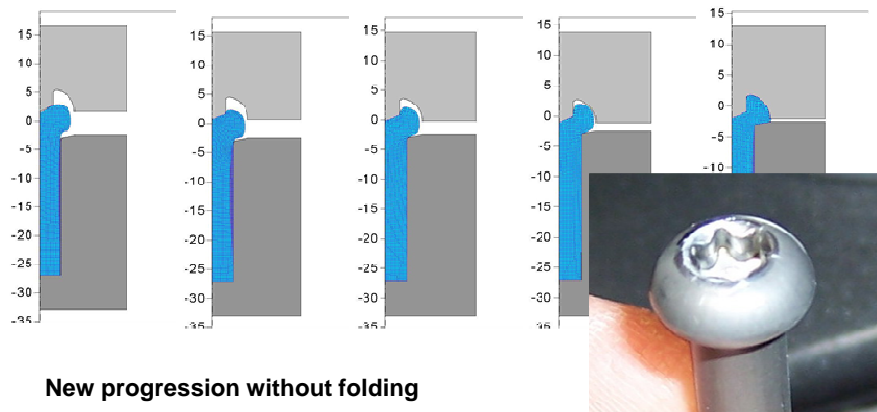

**New progression without folding**

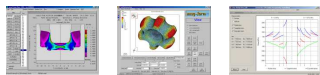

### Application of FEA Simulation in Cold Forging

#### *Production of a hex bolt*

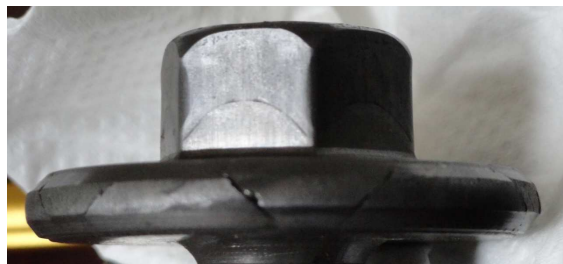

**The hex bolt shows cracks on the surface**

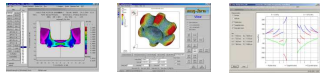

## Application of FEA Simulation in Cold Forging

### Production of a hex bolt

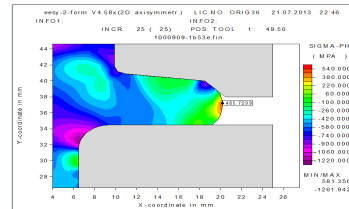
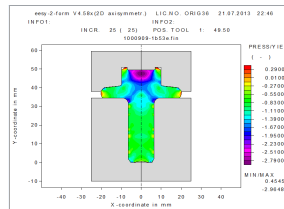

### Stress analysis

After the stress analysis the engineer understands the reason and can change the design to avoid the failure.

**Learning this once the engineer will not make this mistake again.**

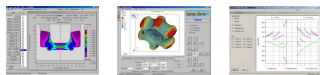

## Application of FEA Simulation in Cold Forging

### Failure of a screw that is not caused by wrong progression



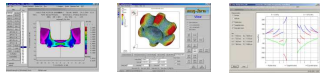

### Application of FEA Simulation in Cold Forging

#### Failure of a screw that is not caused by wrong progression

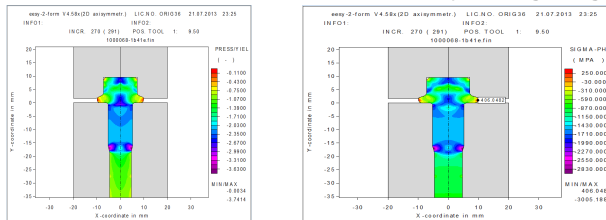

**Stress analysis – all values (tangential stress and ration of hydrostatic pressure to yield stress) are safe**

**In this case the engineer can call the supplier to replace the material directly. This kind of failure is provable a material problem.**

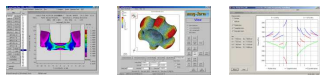

### Application of FEA Simulation in Cold Forging

#### Simulation of a „Brake Piston“

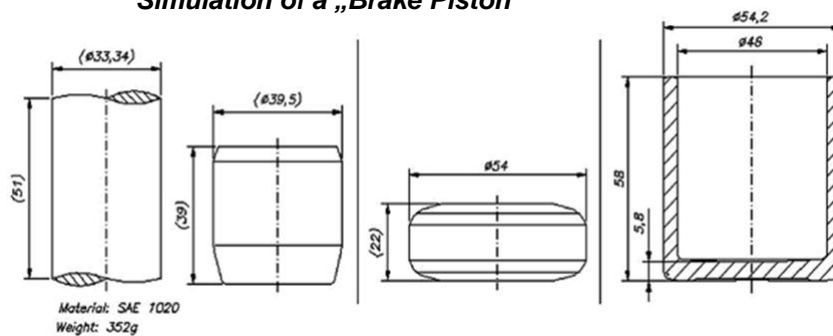

traditionel process

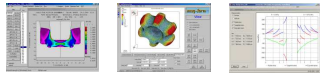

Application of FEA Simulation in Cold Forging  
*Simulation of a „Brake Piston“*

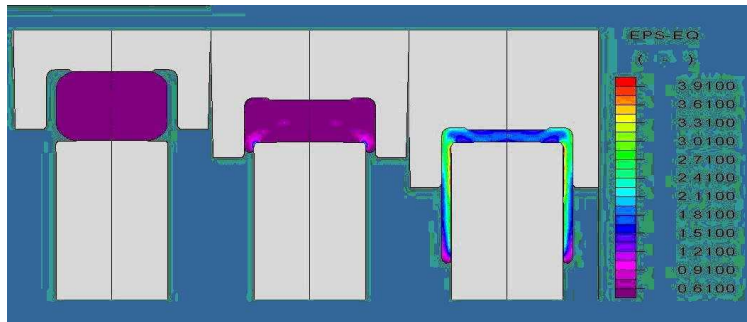

traditionell process

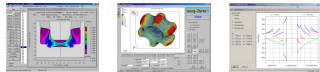

Application of FEA Simulation in Cold Forging  
*Simulation of a „Brake Piston“*

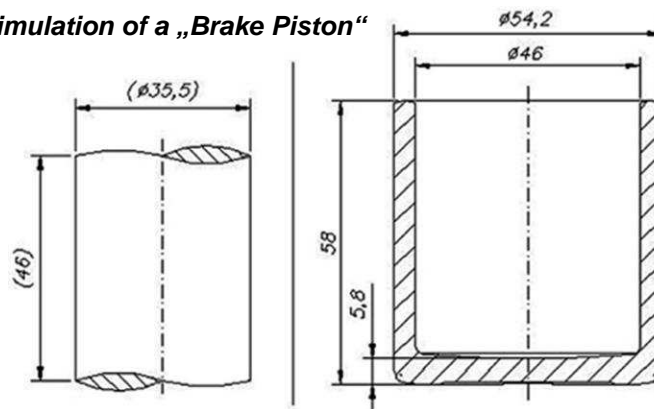

new process – osen-

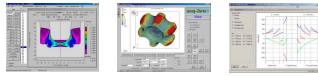

## Application of FEA Simulation in Cold Forging Simulation of a „Brake Piston“

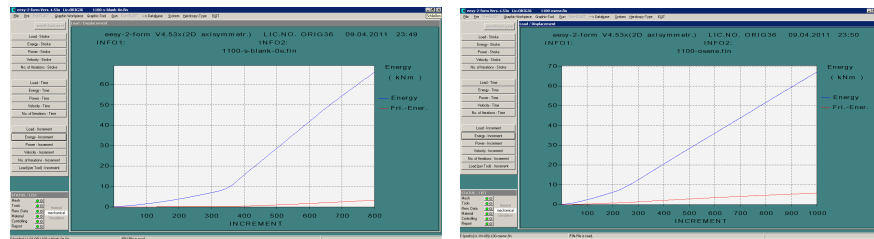

**Comparison – work**

**Backward**

**Osen**

Since both processes need the same work (besides small differences in friction etc) the Osen process requires less load.

**The Osen process requires about 180 to while the backward extrusion requires 450 to.**

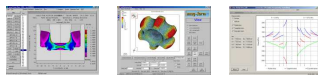

## Application of FEA Simulation in Cold Forging Production of an „inner race“



**Inner race – process development**

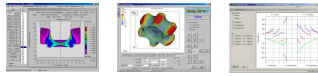

### Application of FEA Simulation in Cold Forging

#### Production of an „inner race“

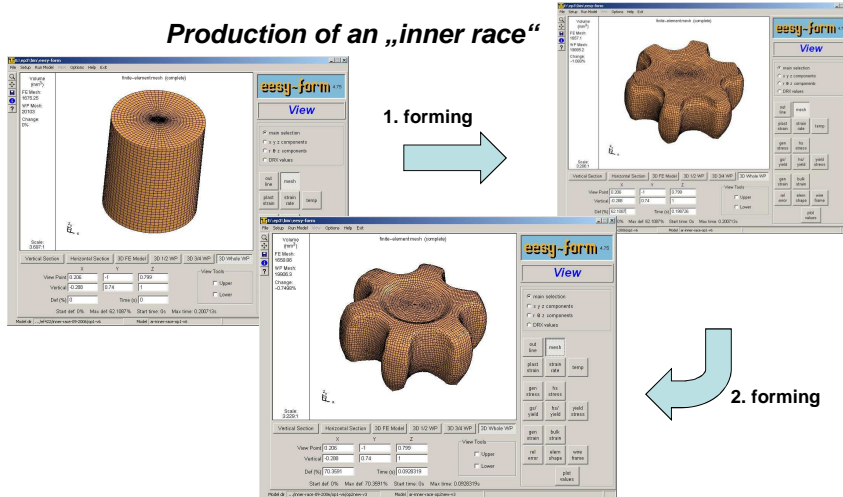

(c) 2014 Dr. Gerhard H. Arfmann, Dr. Michael Twickler  
Presentation, 10.09.2014, Shanghai, PR China

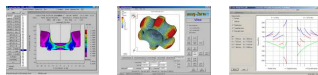

### Application of FEA Simulation in Cold Forging

#### Production of an „inner race“

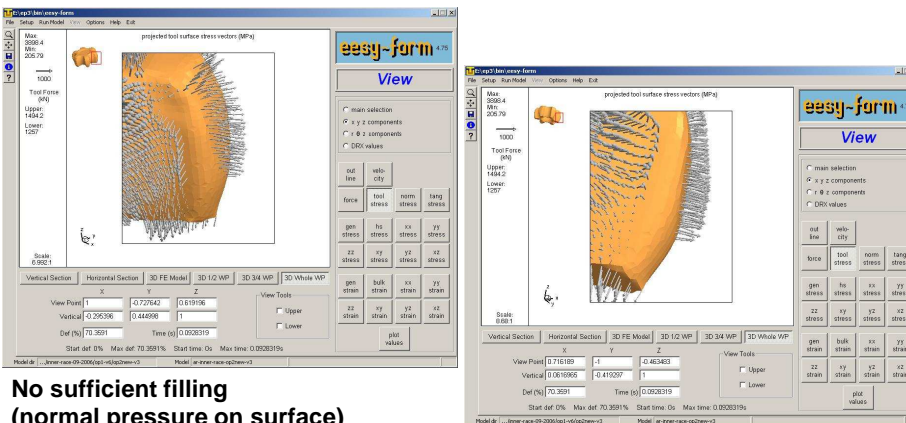

**No sufficient filling  
(normal pressure on surface)**

(c) 2014 Dr. Gerhard H. Arfmann, Dr. Michael Twickler  
Presentation, 10.09.2014, Shanghai, PR China



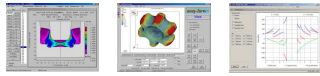

### Application of FEA Simulation in Cold Forging *Production of an „inner race“*



Inner race – process development

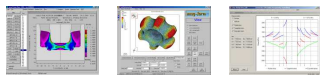

### Application of FEA Simulation in Cold Forging *Production of an hexagonal fastener*

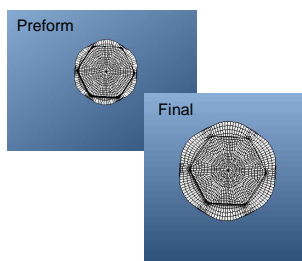

First approach

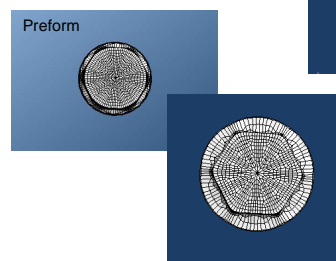

Final approach

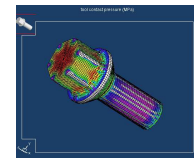
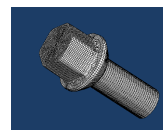

Avoid „flower“ Shape

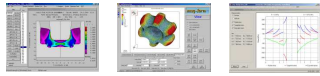

## Conclusion

### Application of FEA Simulation in Cold Forging



After 25 years of usage of FEA software to analyze plastic material flow there is still some discussion about the sense or nonsense of using simulation in forging industry. Still some argue that the systems are too complex to be used others think that they would be not precise enough still.

Scientists sometimes mention that the data and algorithm used are scientifically not really correct.

Despite all these discussions FEA is established as a very useful tool for industry. The examples showed a part of the wide range of **successful application in industry**.

It helps to avoid a lot of costs. It helps to improve technology. And finally despite of some certain “weakness” of FEA it opens the user areas of technology that he would not reach otherwise.

**Today FEA is a “must” for companies who want to be in the lead**

**– who want to win.**

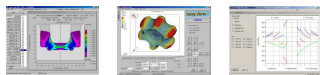

### Application of FEA Simulation in Cold Forging

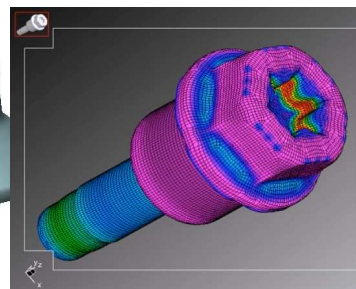
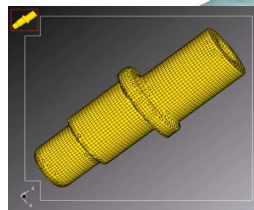
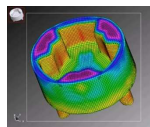
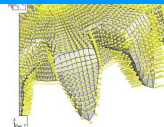

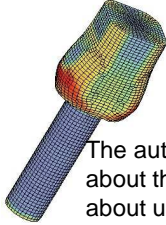

### Acknowledgements

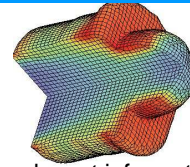

The authors thank their customers for providing them with relevant information about the practical cases and about their general comments about using FEA in their daily work.

This information and the comments are very helpful to improve FEA software and promote its use in presentations like this.

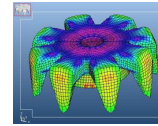

Besides others we would like to mention:

Acopecas, Brasil; XZB, PR China; Barton Cold Forging, UK; Fuchs, Germany;  
Bilstein und Sikermann, Germany; Hema, Germany; Philidas, UK; SQB, PR China;  
Manzato, Brazil; General Screw, PR China; CQB, PR China; Nedschroef, Belgium

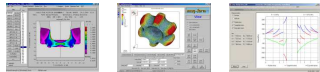

### Trust in "eesy" simulation



Customers are happy to solve their daily problems  
with "eesy"-simulation-software