



## **Eesy-form:**

# **The Results of an European CRAFT-project on 3D – Simulation for the Fasteners Industry**

EC Craft project BE-S2-5114

**Dr. Gerhard H. Arfmann, Dr. Michael Twickler \*)**

### **Participants:**

NUTAP, Schuhl & Co. GmbH (NUTAP), Ernst Rosenbach, Fertigungs- u. Vertriebs Ges. mbH (Rosenbach), OSLAT S.N.C. DI FAZZI F. & CICO G. (OSLAT), MEVI ITALIA S.R.L. (MEVI), CSW Coldform Limited (CSW), Henrob Ltd. (Henrob), Johnson Precision Tooling Ltd. (Johnson), Mauer Metallurgische Verfahrenstechnik GmbH (Mauer), CPM Gesellschaft für Computeranwendung, Prozeß- und Materialtechnik mbH (CPM), The University of Birmingham (UOB), HVU Umformtechnik (HVU) (Subcontractor), serte srl. (serte) (Subcontractor)

### **Summary**

**The general aim of the project was to develop an easy-to-handle software tool focused on special 3D-geometries typical in cold forging and designed for SMEs in the European forging industry to enable them to simulate the forging operations related to the layout design for a progression of a cold formed part.**

The basic research approach was to enhance an existing 3D-simulation code using the Finite Element Method (FEM) by developing additional modules to enable the code to handle all the geometrical and physical boundary conditions typical for cold forging (special 3D-geometries, locally changing friction conditions, etc.) and to combine this code with special pre- and post-processing modules focused on the needs (simple-to-use and simple-to-understand) of the SMEs. This ensured to end up with an easy-to-use simulation tool which can be introduced at typical SMEs and which does not require FEM-specialists at the SMEs for using it in product development.

To check and to verify the development practical tests of complete progressions for existing and/or new parts have been performed at the SMEs' site.

The developed code was implemented at the end of the project in PC environment using LINUX as operating system. This enables the participating SMEs to introduce the system on a low cost computing environment.

The partners agreed to stay together in a USERS Group being open to all interested industries to further develop the system.

\*) CPM GmbH, Germany

## Objectives of the project

In cold forming of fasteners the layout design for a progression of forming stages is based mainly on empirical rules and expensive "Trial and Error" procedures. A better process understanding and the use of modern tools for process layout can bring down the costs and increase the product quality. This is achieved by shortening the time to do the layout, by avoiding testing, by optimising the progression and therefore increasing the tool life and by optimising the product.

In this project special modules for Pre- and Post-processing had to be developed and integrated with an existing 3D- Simulation code. The aim was to develop a simulation tool on the basis of non-linear Finite Element Analysis ( FEM ) which will give the SMEs the ability to optimise their processes by using High Tech Tools and will result in enhanced competitiveness of the companies involved.

The main topics in this development were:

a specific Pre-processing module with a simple partly automated transformation of a simple tool-drawing into a FEM-model

the precise representation of the tooling shape by using a combination of geometric primitives ( partly developed for the existing 3D code )

a post-processing module based on technological aspects which allows a simple automated analysis of critical results

A completely general pre-processing system for 3D modelling was outside the scope of this project. To achieve the objective of producing a user-friendly system for non-specialists the geometries having been considered were restricted to those relevant to the Fasteners industries. These geometries were based on simple primitives such as hexagons, cylinders and other prismatic shapes to allow all 3D parts to be generated automatically from the design drawings

## Scientific and technical description of the project

The specific processes to be simulated with their specific process parameters and the expected output were defined. Such parameters are the material, process temperature, press characteristic and typical shapes of tools. The expected output is geometry, material flow and local plasto-mechanic components (deformation, deformation rate, stresses). The regarded 3D-products are periodically axisymmetric parts. Precise definition of geometry, input parameters needed for simulation (cut off, tooling, material, friction) were fixed as well as the required output. Possible values to prove the results were discussed (geometry, material flow, tool defects, typical faults). The restrictions to a general 3D-layout because of the regarded parts being periodically axisymmetric were discussed and agreed by the SMEs.

CPM and the SMEs looked for typical products and processes as well as for their typical production problems. From this discussion they chose one product for each SME of which the production process had to be investigated in detail.

CPM and the SMEs fixed the required measurements and the form of documentation to make the tests comparable and to give the best possible input for the later analysis with the simulation software.

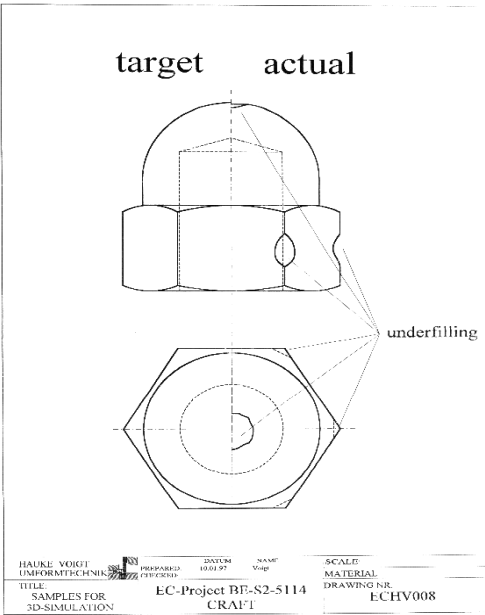

Fig. 1 shows a typical cold formed part (nut) with typical underfilling

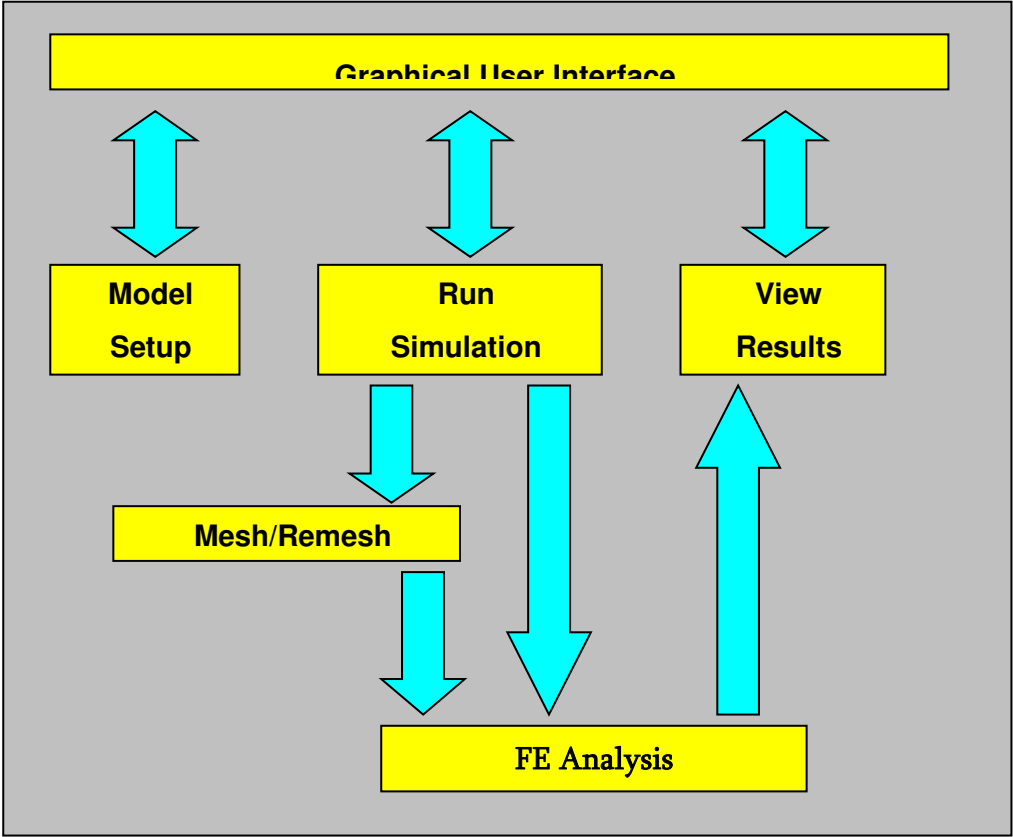

Fig 2 shows the system structure

The following figures (3-6) show first layouts of input masks and tool representations as well as the definition of machine characteristics etc..

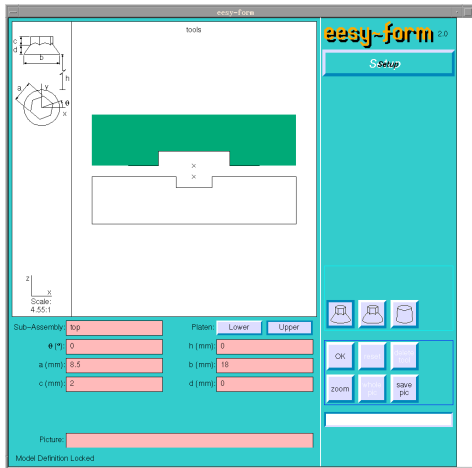

Fig 3 Input mask providing a first module to generate a tool

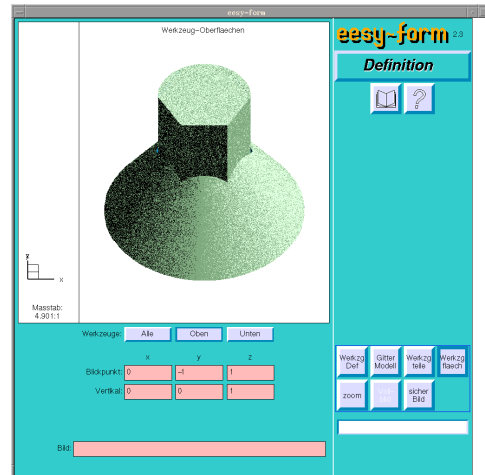

Fig 4 3D view of the tool

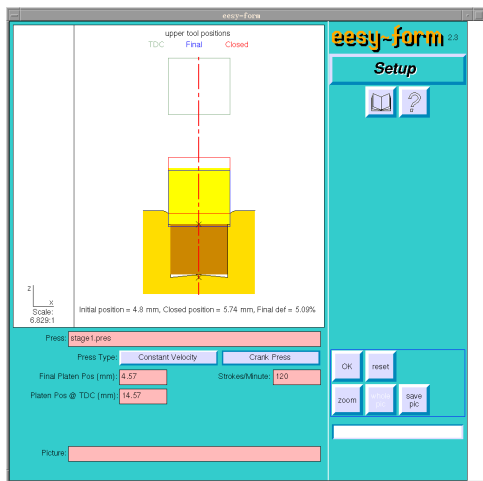

Fig 5 Definition of machine characteristic (crank press)

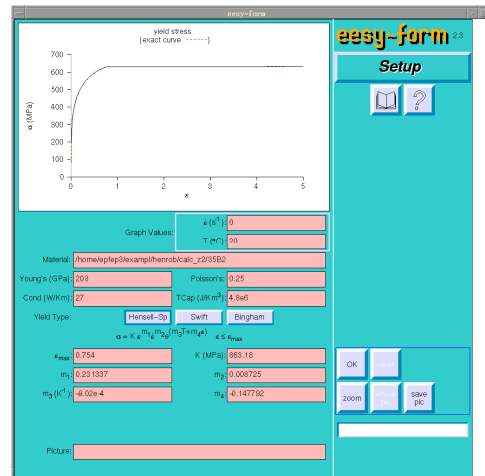

Fig 6 Definition of material properties (yield stress-strain curve)

University of Birmingham and CPM performed first simulations with the new developed code.

The figures (7-9) show a first application of the developed system. To check the possible graphical representations of a defined model and the simulation results a simple purely axisymmetric component was chosen. Although this part was axisymmetric it was modelled for the simulation as a fully 3D component. By doing so a first assessment of the simulation results (stress, strain, velocity, etc.) and of the 2 1/2 D remeshing was possible without modelling a complex 3D structure.

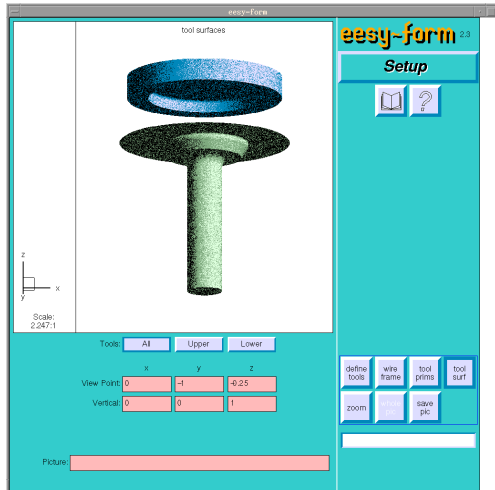

Fig 7 first 3D simulations of a cold forming operation (tooling)

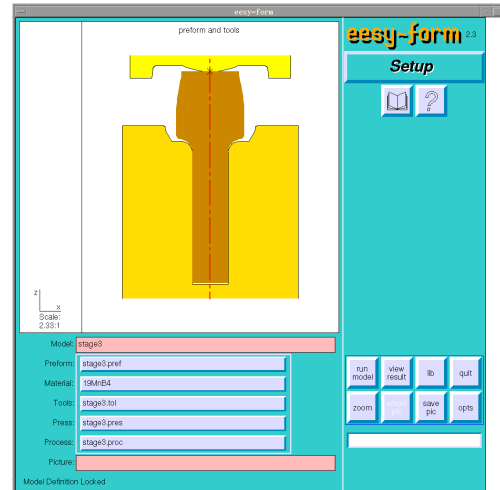

Fig 8 first 3D simulations of a cold forming operation (setup)

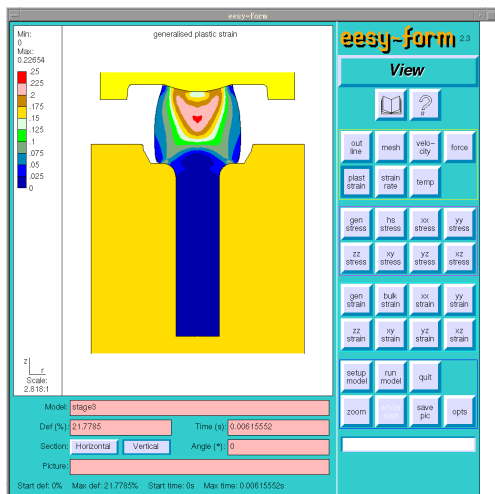

Fig 9 first 3D simulations of a cold forming operation (strain distribution)

Further simulations were performed with the new developed code.

Figures 10-22 give an overview of the developed input and graphical output modules. Figure 10 shows the range of developed tool subassemblies available to define most of the typical toll shapes in Fasteners industries. All of them can be defined by giving only a small number of parameters and dimensions. Graphical control is given directly while defining or changing any input. To show a tool set wire frame and solid surface representation are available (fig. 11-13).

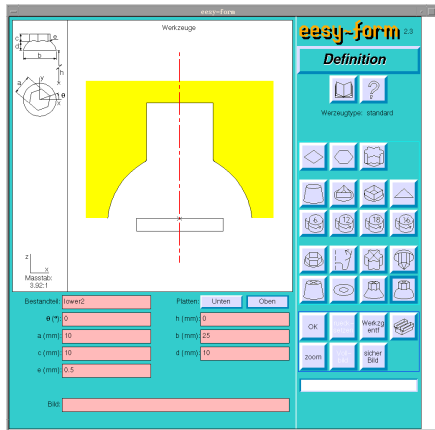

Fig 10 Input mask showing the various tool shape generation module

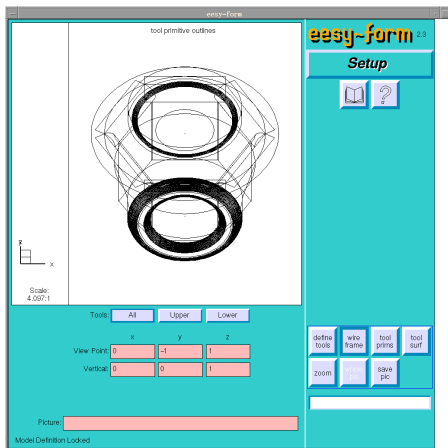

Fig 11 ref. Part: Tooling (wire frame – side view)

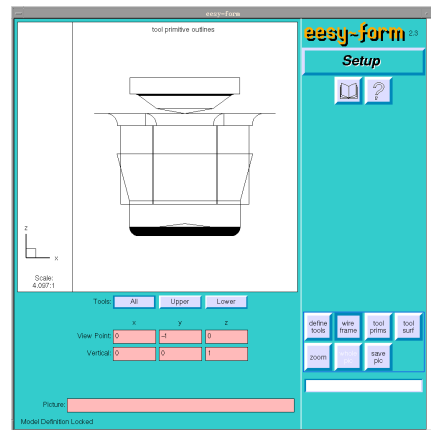

Fig 12 ref. Part: Tooling (wire frame – 3D view)

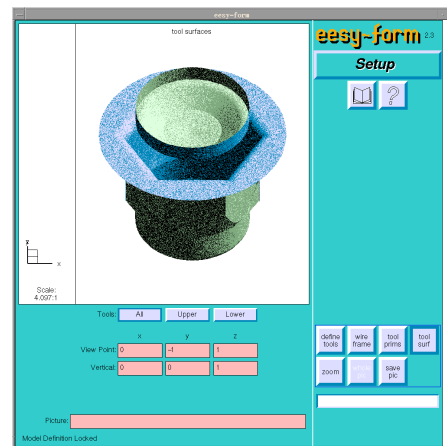

Fig 13 ref. Part: Tooling (tool surface - 3D view)

The graphical representation of simulation results can be done generally for vertical sections at any angle and for horizontal sections at any height to enable a complete 3D part analysis. In figure 14-19 the complete set of features to display simulation results can be seen. These figures show typical results like final geometry (fig.14,15), material flow (fig. 16,17) and distribution of plastic strain (fig.18,19).

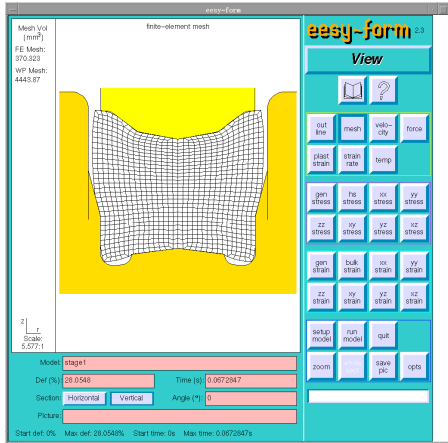

Fig 14 ref. Part: Mesh (side view)

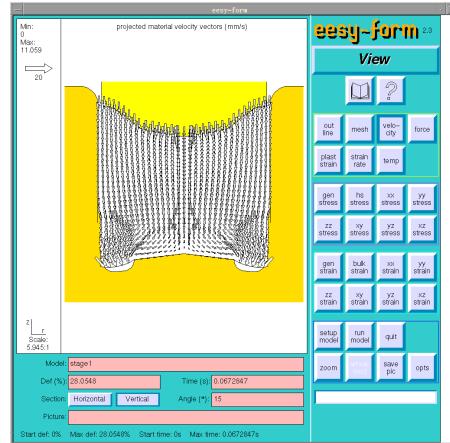

Fig 17 ref. Part: Velocity (cross corner – 15°)

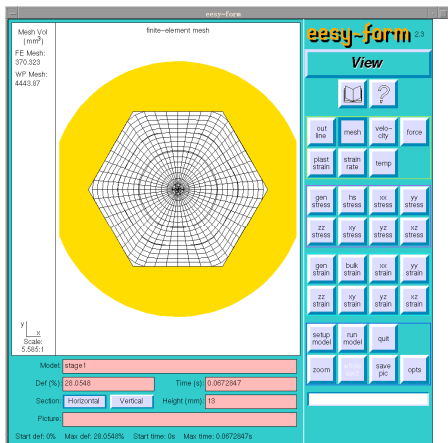

Fig 15 ref. Part: Mesh (top view)

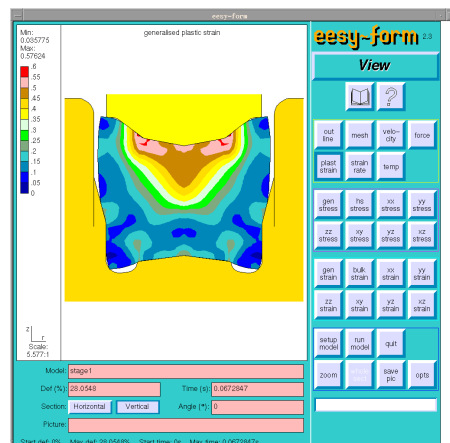

Fig 18 ref. Part: Strain (cross flat – 0°)

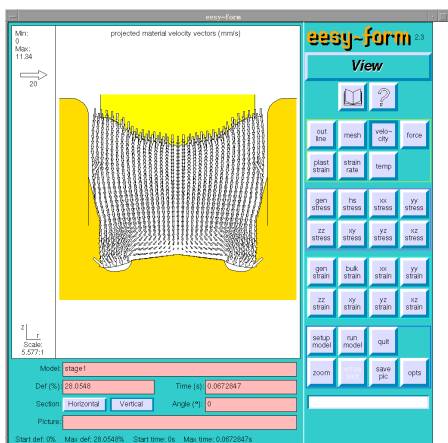

Fig 16 ref. Part: Velocity (cross flat – 0°)

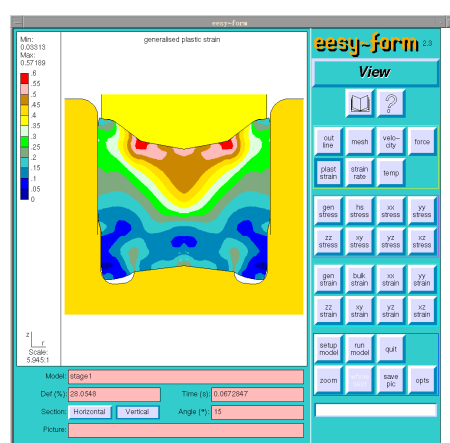

Fig 19 ref. Part: Strain (cross corner – 15°)

CPM resumed the results of the simulation applications.

Together with all partners these results were discussed and hints for necessary software changes and/or and for required changes for further practical tests were discussed.

At this stage the actual development of PC systems gave the possibility to run the system also on PC systems using LINUX as operating system.

CPM and the University of Birmingham coded final changes and corrections in the developed modules.

**The partners agreed to set up a USERS Group to continue the work done in the project. This group will be open to further industrial partners and will co-ordinate the exploitation of the system and further developments.**

## **Results and Conclusions**

The objectives of the project could be reached. The system includes easy to handle pre- and post-processing facilities. The 2 ½ D remeshing could be implemented successfully. The necessary add-on developments to the basic system could be done with success.

The industrial tests could be completed successfully and the results could be used for the developments. First simulations showed good results. The system could even be implemented in low cost PC environment.

The co-operation between the partners was excellent and therefor the planned work in the Users Group promises to be successful. For the partners represent a wide range of cold forming production in Europe the partners expect that the exploitation will be without problems. The result of the project showed that all partners have good competence in their field and are able to handle a R&D project of this magnitude. Therefor they will be able to use the results of the project for their own benefit and to transfer the technology to other industries

## **Acknowledgements**

**CPM on behalf of all the partners express their acknowledgements to the European Commission enabling all partners to end up with this successful project by providing funding under the Brite-EuRam III - CRAFT program.**